



Greaney Concrete Products
Advanced equipment & superior products since 1976

Manhole Riser

Approx Weight:
See Table

Drawn By:
TGL

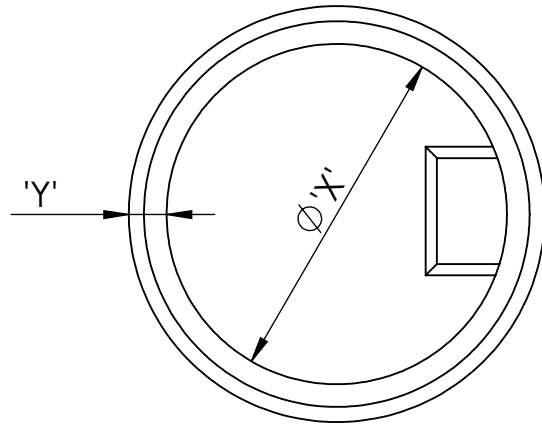

'X' Internal Diameter of Chamber Rings	'Y' Wall Thickness (Approx)	'Z' Height (Approx Weight in kg's)			
		1.00m	0.75m	0.50m	0.25m
900mm	100mm	780kg	585kg	390kg	195kg
1050mm	100mm	901kg	675kg	450kg	225kg
1200mm	135mm	1100kg	825kg	550kg	275kg
1500mm	150mm	1918kg	1437kg	959kg	479kg

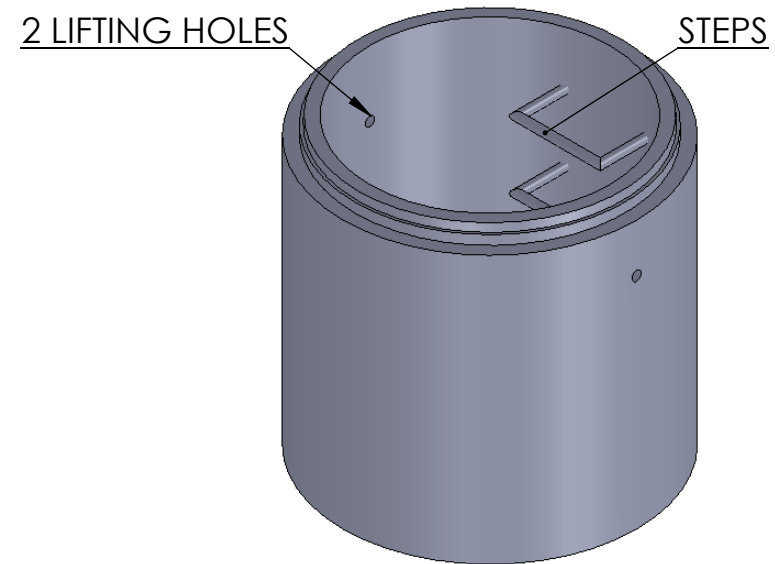
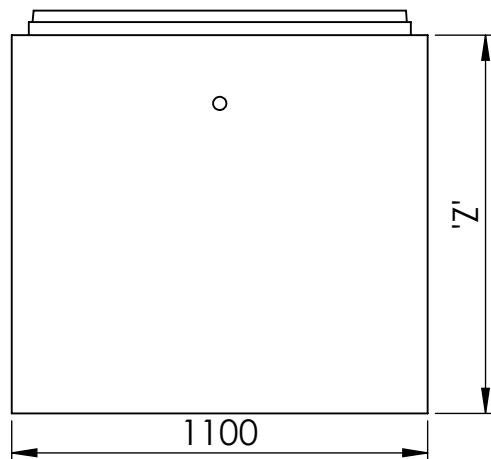

The information contained in this drawing was up to date at the time of going to print. Profile, sizes and weights are given as an indication only. Greaney Concrete Products Ltd reserves the right to modify these at any time without notice.